

PRODUCT INFORMATION PACKET

Model No: 286TTFCD6028

Catalog No: GT1231A

30 HP General Purpose Motor, 3 phase, 1800 RPM, 230/460 V, 286TC Frame, TEFC
Three Phase TEFC Motors



Nameplate Specifications

Output HP	30 Hp	Output KW	22.4 kW
Frequency	60 Hz	Voltage	230/460 V
Current	71.0/35.5 A	Speed	1770 rpm
Service Factor	1.15	Phase	3
Efficiency	93.6 %	Power Factor	84
Duty	Continuous	Insulation Class	F
Design Code	B	KVA Code	G
Frame	286TC	Enclosure	Totally Enclosed Fan Cooled
Thermal Protection	No	Ambient Temperature	40 °C
Drive End Bearing Size	6311	Opp Drive End Bearing Size	6211
UL	Listed	CSA	Y
CE	Y	IP Code	55
Hazardous Location	DIVISION 2 T2B		

Technical Specifications

Electrical Type	Squirrel Cage Inverter Rated	Starting Method	Line Or Inverter
Poles	4	Rotation	Selective Clockwise
Resistance Main	.27 Ohms	Mounting	Rigid Base
Motor Orientation	Horizontal	Drive End Bearing	Ball
Opp Drive End Bearing	Ball	Frame Material	Cast Iron
Shaft Type	T	Overall Length	28.14 in
Frame Length	12.91 in	Shaft Diameter	1.875 in
Shaft Extension	4.62 in	Assembly/Box Mounting	F1/F2 CAPABLE
Outline Drawing	SS620701-200	Connection Drawing	EE7308AA

4

3

2

1

OUTLINE

B

B

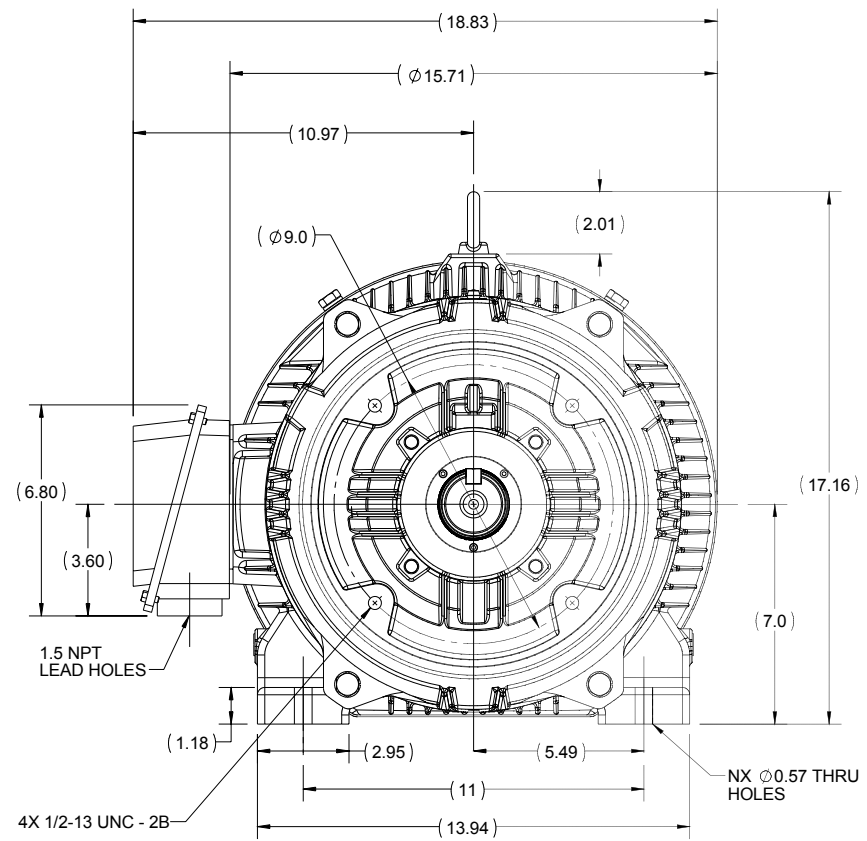
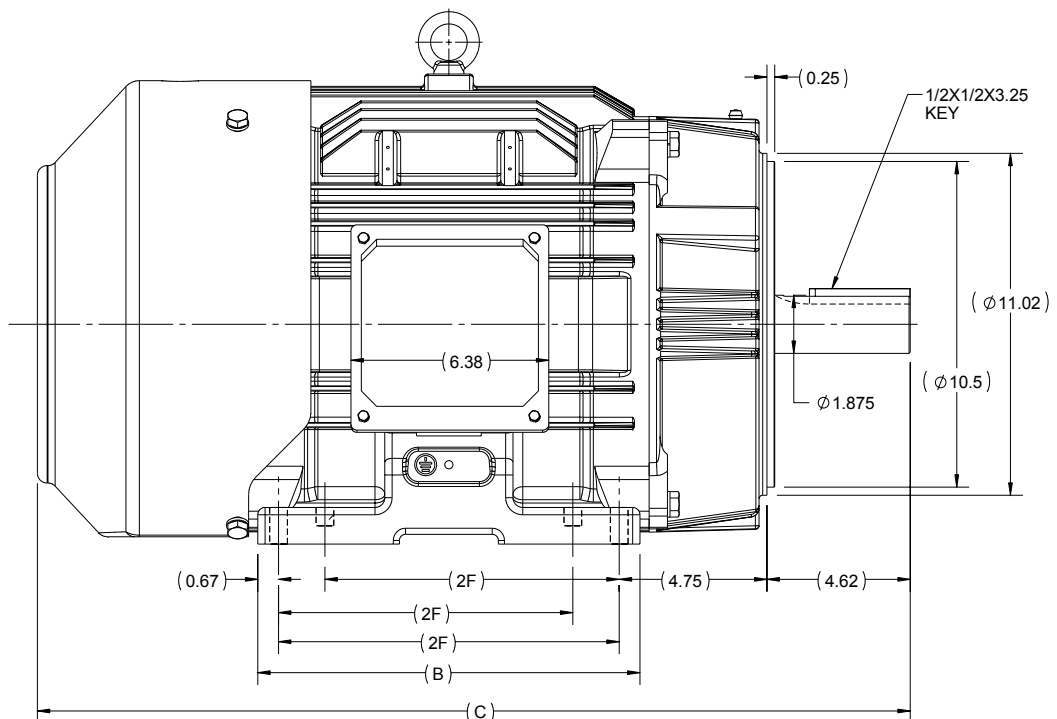

A

A

286	12.32	28.14	11	8
284	10.82	26.65	9.5	4
FRAME	B	C	2F	N

DRAWING REVISION A	REVISION BY UDAY	DATE 08/09/2015
ECO ECO-0084584	APPROVED BY SBD	DATE 08/09/2015
ECO DESCRIPTION		
<small>COPYRIGHT REGAL BELOIT AMERICA, INC. ALL RIGHTS RESERVED. PROPRIETARY AND CONFIDENTIAL INFORMATION - THIS DOCUMENT IS THE PROPERTY OF REGAL BELOIT AMERICA, INC. ("OWNER") AND CONTAINS OWNER'S PROPRIETARY INFORMATION. ANY PERSON, CORPORATION OR OTHER FIRM RECEIVING IT IS DEEMED, BY RECEIVING IT, TO AGREE THAT IT, AND/OR ANY PART OF IT, SHALL NOT BE DISCLOSED TO ANY PERSON, CORPORATION OR OTHER ENTITY, DUPLICATED, AND/OR USED, EXCEPT AS EXPRESSLY APPROVED IN WRITING IN ADVANCE BY OWNER. THIS DOCUMENT SHALL BE RETURNED TO OWNER UPON REQUEST. IT MAY BE SUBJECT TO CERTAIN RESTRICTIONS UNDER APPLICABLE EXPORT CONTROL LAWS AND REGULATIONS.</small>		

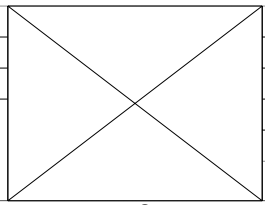

DRAWN BY SMAR
DATE 06/07/2015
APPROVED BY SBD
DATE 06/07/2015
REFERENCE
THIRD ANGLE PROJECTION

 REGAL-BELOIT CORPORATION	
DESCRIPTION	
OUTLINE	
284/286TC FR-TEFC-CAST IRON	
MATERIAL	PROCESS/FINISH
SIZE B	DRAWING NUMBER SS620701
	SHEET 1 OF 1



LOW VOLTAGE



HIGH VOLTAGE



DRAWING REVISION K	REVISION BY AJW	DATE 07-17-2015
ECO ECO-0081632	APPROVED BY T. VUE	DATE 07-17-2015
ECO DESCRIPTION REV'D IEC MARKINGS PER IEC 60034-8		
<small>COPYRIGHT REGAL BELOIT AMERICA, INC. ALL RIGHTS RESERVED. PROPRIETARY AND CONFIDENTIAL INFORMATION - THIS DOCUMENT IS THE PROPERTY OF REGAL BELOIT AMERICA, INC. ("OWNER") AND CONTAINS OWNER'S PROPRIETARY INFORMATION. ANY PERSON, CORPORATION OR OTHER FIRM RECEIVING IT IS DEEMED, BY RECEIVING IT, TO AGREE THAT IT, AND/OR ANY PART OF IT, SHALL NOT BE DISCLOSED TO ANY PERSON, CORPORATION OR OTHER ENTITY, DUPLICATED, AND/OR USED, EXCEPT AS EXPRESSLY APPROVED IN WRITING IN ADVANCE BY OWNER. THIS DOCUMENT SHALL BE RETURNED TO OWNER UPON REQUEST. IT MAY BE SUBJECT TO CERTAIN RESTRICTIONS UNDER APPLICABLE EXPORT CONTROL LAWS AND REGULATIONS.</small>		

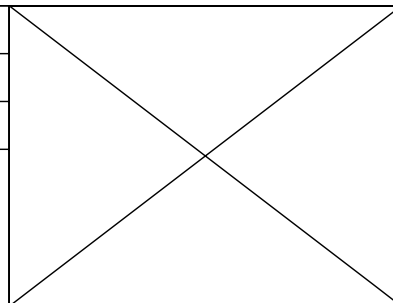

DRAWN BY LZ	Regal Beloit America, Inc.	
DATE 01-12-1994		
APPROVED BY GK	DESCRIPTION CONN DIAGRAM-EXTERNAL 3Ø-2/1 DELTA-12 LEADS	
DATE 01-14-1994		
REFERENCE	MATERIAL	PROCESS/FINISH
THIRD ANGLE PROJECTION	SIZE A	DRAWING NUMBER EE7308AA
		SHEET 1 OF 1



P.O. BOX 8003
WAUSAU, WI 54401-8003
PH. 715-675-3311

DATA VOLTS: 460

CERTIFICATION DATA SHEET

CUSTOMER P.O. #:
 ORDER #: A-EE7308AA
 REFERENCE MODEL #: 2861TFDD06028
 CONN. DIAGRAM: B-SS620706
 CAT #: GT1231A
 OUTLINE: HE31804006 NONE 2 CUSTOMER PART #:
 WINDING: HE31804006 NONE 2 MOUNTING: F1/F2 CAPABLE
 SPEED:
 TYPICAL MOTOR PERFORMANCE DATA

HP	KW	SYNC RPM	FL RPM	FRAME	ENCLOSURE	TYPE	KVA CODE	DESIGN	
30	22.4	1800	1775	286TC	TEFC	TFC	G	B	
PH	HZ	VOLTS	AMPS	START TYPE	DUTY	INSL	S.F.	AMB	ELEV.
3	60/50	230/460#190/380	72.5/36.5#3/36.5	LINE OR INVERTER	CONT	F	1.15	40	3300
	F.L. EFF	93.6	3/4 LD EFF	93.6	1/2 LD EFF	93.0	GTD EFF	ELECT. TYPE	
	F.L. PF	83.0	3/4 LD PF	78.0	1/2 LD PF	67.5	93.0	SQ CAGE INV RATED	
	F.L. TORQUE	LR AMPS @ 460 V	LR TORQUE	B.D. TORQUE	F.L. RISE (°C)				
	89.0 LB-FT	217	178 LB-FT	200%	227 LB-FT	255%	65		
	@ 3 FT.	POWER	ROTOR WK²	MAX. LOAD WK²	SAFE STALL TIME	STARTS/HOUR	MOTOR WGT		
	68 DBA	77 DBA	5.7 LB-FT²	225 LB-FT²	20 SEC.	2	600 LB.		

*** SUPPLEMENTAL INFORMATION ***

DE BRACKET TYPE	ODE BRACKET TYPE	MOUNT TYPE	MOTOR ORIENTATION	SEVERE DUTY	HAZARDOUS LOCATION	DRIP COVER	SCREENS	PAINT
C-FACE	STANDARD	RIGID	HORIZONTAL	NO	NONE	NO	NONE	BLUE (ENAMEL)
BEARINGS	GREASE	SHAFT TYPE	SPECIAL DE	SPECIAL ODE	SHAFT MATERIAL	FRAME MATERIAL		
DE BALL 6311	POLYREX EM	T	NONE	NONE	1045 HOT ROLLED (C-204)	CAST IRON		

THEMOSTATS	PROTECTORS	WDG RTD's	BRG RTD's	THERMISTORS	CONTROL	SPACE HEATERS
NONE	NOT	NONE	NONE	NONE	FALSE	NA
R1 (ohms/ph)	R2 (ohms/ph)	X1 (ohms/ph)	X2 (ohms/ph)	Xm (ohms/ph)	VIBRATION (in/sec)	FLOAT
0.168	0.111	0.617	0.851	16.727	0.150	ODE

INVERTER TORQUE: CONSTANT 10:1
 INV. HP SPEED RANGE: NONE

ENCODER: NONE
 NONE
 NONE
 BRAKE: NONE
 NONE
 NONE
 NONE PPR

PREPARED BY: FAREEDA DUDEKULA
 DATE: 5/3/2018

FORM: 3531 REV. 4 2/27/06

UL: V-INS, CONST UL REC
 FT-LB: NA
 VOLTAGE: NONE
 HZ:

Data Sheet

Date: 5/3/2018

2861TFCD6028

Customer:
 Attention:
 Submitted by: FAREEDA DUDEKULA



Submital
 Data @ 460 V

Load	0%	25%	50%	75%	100%	115%	125%	LR
Current (Amps)	16.0	17.8	22.5	28.9	36.3	41.1	44.4	217
Torque (ft-lb)	0.00	22.0	44.0	66.5	89.0	102	111	178
RPM	1800	1795	1788	1782	1775	1,770	1768	0
Efficiency (%)		89.5	93.0	93.6	93.6	93.3	93.0	
P.F. (%)	5.0	44.5	67.5	78.0	83.0	85.0	85.5	36.0

Motor Speed Data

	LR	Pull-Up	BD	Rated	Idle
Speed (RPM)	0	900	1650	1775	1800
Current (Amps)	217	180	129	36.3	16.0
Torque (ft-lb)	178	151	227	89.0	0.00

Information Block

HP	30.0			
Sync. RPM	1800			
Frame	286182TFC6080			
Enclosure	TEFC			
Construction	TFC			
Voltage	230/460#190/380 V			
Frequency	60 Hz			
Design	B			
LR Code letter	G			
Service Factor	1.15			
Temp Rise @ FL	65 °C			
Duty	CONT			
Ambient	40 °C			
Elevation	1,000 feet			
Rotor/Shaft wk²	5.7 Lb-Ft²			
Ret Wdg	HE31804006 NONE			
Sound Pressure @ 1M	68 dbA			
VFD Rating	CONSTANT 10:1			
Outline Dwg	B-SS620706			
Conn. Diag	A-EE7308AA			
Additional Specifications:				
0				
0				
R1	R2	X1	X2	Xm
0.1680	0.1110	0.6170	0.8510	16.7270
EQUIV CKT (OHMS / PHASE)				

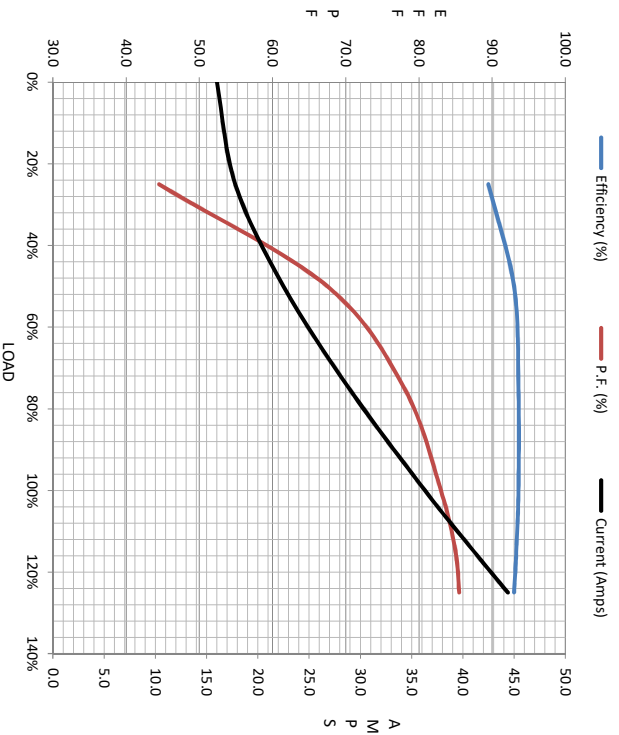

Speed - Torque Curve

